

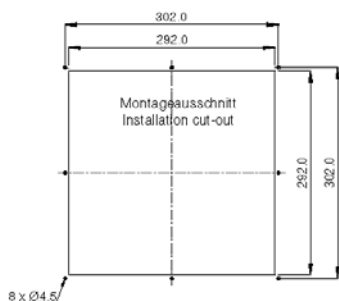

## LÜFTER/FAN GV 800

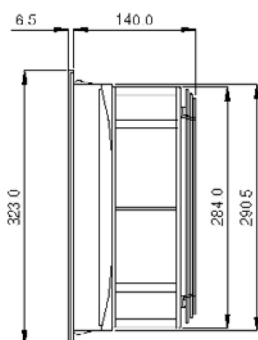

Durch drehen des Motors kann der Lüfter von blasend auf saugend umgestellt werden  
Fan can be converted from blowing to sucking by turning the motor

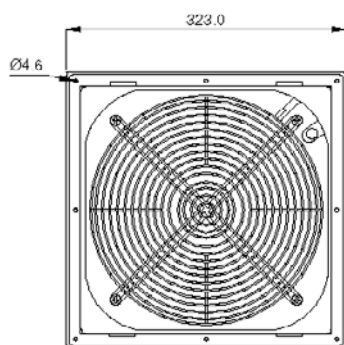

<b>Betriebsspannung/Voltage</b>	230 V, 50/60 Hz / 24 V DC
<b>Leistung/Power input</b>	136/185 W / 105 W
<b>Stromaufnahme/Amperage</b>	0,61/0,82 A / 5,0 A
<b>Drehzahl/Speed</b>	2500/2600 min <sup>-1</sup> / 2750 min <sup>-1</sup>
<b>Temperaturbereich/Temp. range</b>	-10... + 55°C
<b>Lebensdauer/Service life</b>	40.000 h
<b>Luftleistung (freiblasend) Air flow free air</b>	930/970 m <sup>3</sup> /h incl. GF 700 K: 610/640 m <sup>3</sup> /h
<b>Schallpegel/Noise level</b>	69 dB (A) / 70 dB (A)
<b>Farbe/Colour</b>	RAL 7035 (Standard)
<b>Schutzart/-klasse Protection type/class</b>	IP 54, 1
<b>Gewicht/Weight</b>	4,6 kg
<b>Maße/Dimensions</b>	323 x 323 mm
<b>Einbaumaß/Installation cut-out</b>	292 mm
<b>Einbautiefe/Installation depth</b>	140 mm
<b>Approbation</b>	CE, (UL optional)
<b>Passender Austrittsfilter Suitable exhaust filter</b>	GF 700K

Artikel-Bez. Type	Artikel-Nr. Order no.	Bezeichnung Description
GV 800	102223	Lüfter/Fan
GV 800-24 VDC	110143	Lüfter/Fan
GF 700K	100626	Austrittsfilter/exhaust filter